

PARTS LIST							LENGTH	UNIT WT.	NET WT.
1	1	X-251012		BALLAST TRAY WELDMENT - SITE PRO 1			36.58	36.58	
2	4	CSRT-PCB	P-CSRT-PCB	CSRT PIPE CLAMP BRACKET KIT			4.25	16.98	
3	4	G1202		1/2" x 2" HDG HEX BOLT GR5		2 in	0.18	0.70	
4	4	G12FW		1/2" HDG USS FLATWASHER		3/32 in	0.03	0.14	
5	4	G12LW		1/2" HDG LOCKWASHER		1/8 in	0.01	0.06	
6	4	G12NUT		1/2" HDG HEAVY 2H HEX NUT		7/8 in	0.07	0.29	
							TOTAL WT. #	55.88	

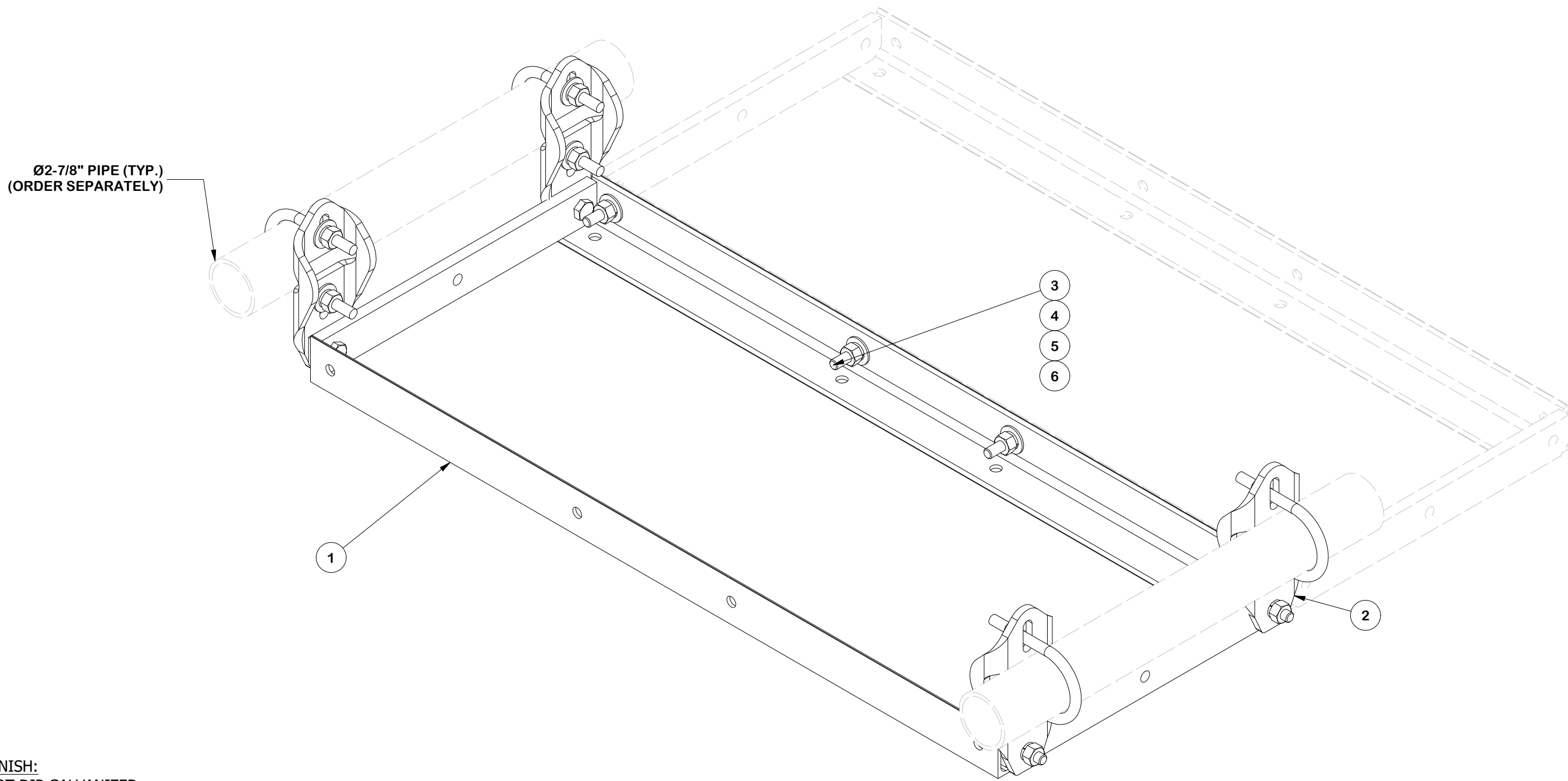

FINISH:
HOT DIP GALVANIZED.

TOLERANCE NOTES

TOLERANCES ON DIMENSIONS, UNLESS OTHERWISE NOTED ARE:
 SAWED, SHEARED AND GAS CUT EDGES (± 0.030 ")
 DRILLED AND GAS CUT HOLES (± 0.030 ") - NO CONING OF HOLES
 LASER CUT EDGES AND HOLES (± 0.010 ") - NO CONING OF HOLES
 BENDS AND ANGLES ARE $\pm 1/2$ DEGREE
 ALL OTHER MACHINING (± 0.030 ")
 ALL OTHER ASSEMBLY (± 0.060 ")

PATENT INFORMATION: WWW.SITEPRO1.COM/PATENTS

PROPRIETARY NOTE:
 THE DATA AND TECHNIQUES CONTAINED IN THIS DRAWING ARE PROPRIETARY INFORMATION OF VALMONT INDUSTRIES AND CONSIDERED A TRADE SECRET. ANY USE OR DISCLOSURE WITHOUT THE CONSENT OF VALMONT INDUSTRIES IS STRICTLY PROHIBITED.

DESCRIPTION			
CSRT SERIES™ 4' TRAY W / ATTACHMENT HARDWARE			
CPD NO.	DRAWN BY	ENG. APPROVAL	
NCS	SDR 12/10/2025	12/18/2025	
CLASS	SUB	DRAWING USAGE	CHECKED BY
87	02	CUSTOMER	JET 12/18/2025

 A valmont COMPANY	Engineering Support Team: sp1engineering@valmont.com
	PART NO. CSRT-4-4T
DWG. NO. CSRT-4-4T	PAGE 1 OF 2

PARTS LIST						
ITEM	QTY	PART NO.	PART DESCRIPTION	LENGTH	UNIT WT.	NET WT.
1	1	X-CSRT-PCB	PIPE CONNECTION BRACKET	12 in	3.01	3.01
2	1	X-UB1300	1/2" X 3" X 5" X 2" GALV U-BOLT		0.74	0.74
3	1	G1202	1/2" x 2" HDG HEX BOLT GR5	2 in	0.18	0.18
4	2	G12FW	1/2" HDG USS FLATWASHER	3/32 in	0.03	0.07
5	3	G12LW	1/2" HDG LOCKWASHER	1/8 in	0.01	0.04
6	3	G12NUT	1/2" HDG HEAVY 2H HEX NUT	7/8 in	0.07	0.21
					TOTAL WT. #	4.25

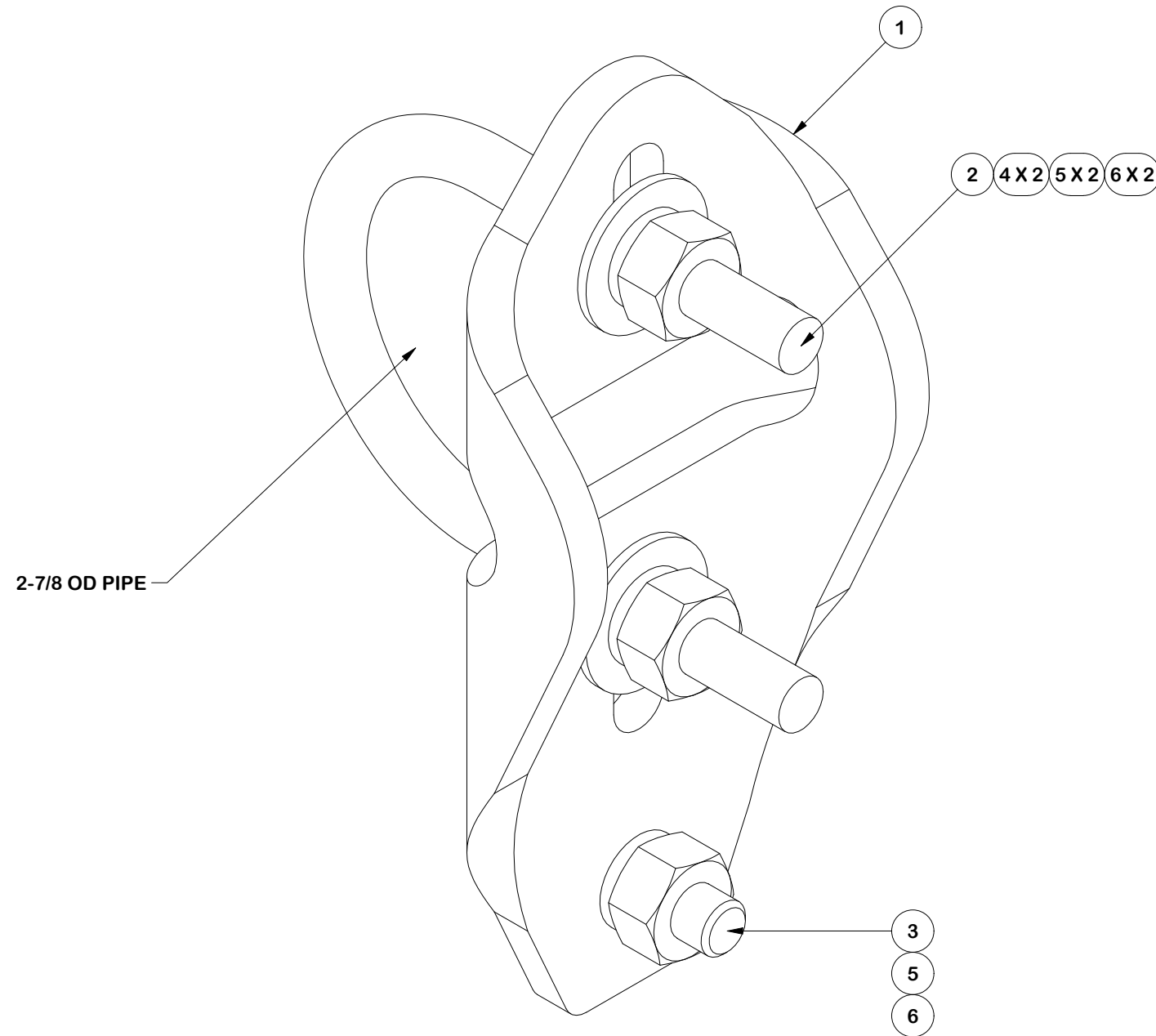

FINISH:
HOT DIP GALVANIZED.

TOLERANCE NOTES

TOLERANCES ON DIMENSIONS, UNLESS OTHERWISE NOTED ARE:
 SAWED, SHEARED AND GAS CUT EDGES ($\pm 0.030"$)
 DRILLED AND GAS CUT HOLES ($\pm 0.030"$) - NO CONING OF HOLES
 LASER CUT EDGES AND HOLES ($\pm 0.010"$) - NO CONING OF HOLES
 BENDS AND ANGLES ARE $\pm 1/2$ DEGREE
 ALL OTHER MACHINING ($\pm 0.030"$)
 ALL OTHER ASSEMBLY ($\pm 0.060"$)

PATENT INFORMATION: WWW.SITEPRO1.COM/PATENTS

PROPRIETARY NOTE:
 THE DATA AND TECHNIQUES CONTAINED IN THIS DRAWING ARE PROPRIETARY INFORMATION OF VALMONT INDUSTRIES AND CONSIDERED A TRADE SECRET. ANY USE OR DISCLOSURE WITHOUT THE CONSENT OF VALMONT INDUSTRIES IS STRICTLY PROHIBITED.

DESCRIPTION
**CSRT SERIES™ 4' TRAY
 W / ATTACHMENT HARDWARE**



Engineering Support Team:
 sp1engineering@valmont.com

CPD NO. NCS	DRAWN BY SDR 12/10/2025	ENG. APPROVAL 12/18/2025
CLASS 87	SUB 02	DRAWING USAGE CUSTOMER
CHECKED BY JET 12/18/2025		

PART NO. CSRT-PCB	PAGE 2 OF 2
DWG. NO. CSRT-4-4T	